

FEIDER

MACHINES

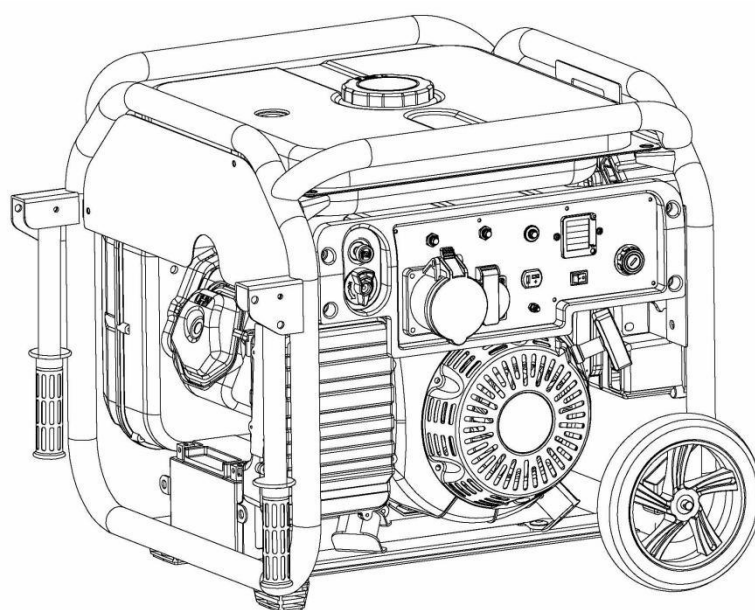

PETROL INVERTER GENERATOR

FGHI7000ES

USER GUIDE

CAUTION: Read this manual before using this machine!

CONTENTS

1. SAFETY INSTRUCTIONS.....	3
2. QUICK START.....	7
3. SAFETY LABEL POSITION.....	9
4. PARTS IDENTIFICATION.....	10
5. CHECK BEFORE OPERATION.....	10
6. START THE ENGINE.....	13
7. OPERATING THE GENERATOR.....	15
8. SHUT OFF THE ENGINE.....	20
9. MAINTENANCE.....	20
10. TRANSPORTATION/WAREHOUSING.....	24
11. TROUBLESHOOTING.....	25
12. SPECIFICATIONS.....	27
13. CIRCUIT DIAGRAM.....	28
14. DECLARATION OF CONFORMITY.....	29
15. WARRANTY.....	30
16. PRODUCT FAILURE.....	31
17. WARRANTY EXCLUSIONS.....	32

1. SAFETY INSTRUCTIONS



WARNING:

1. Attention! Exhaust gases are toxic. Do not operate the generator in a room without ventilation system!
2. Children should be protected by keeping them at a safe distance from the generator set!
3. Refilling of the generating sets are not allowed during the operation!
4. If the generator will be mounted in a closed room, relevant safety regulations against fire and explosion should be followed!
5. Do not connect to household circuit!
6. Do not use in wet condition!
7. Keep in flammable away!
8. When refuelling:
 - a) stop engine;
 - b) no smoking;
 - c) do not spill.

General security instructions

- The operator must know the principles of functioning and the structure of the generator and the motor. He must know how to stop the motor in case of urgency and how to manipulate the controls.
- Never let children use this device.
- Never let people who do not know these instructions use this device. Local regulations may impose restrictions on the age of the user.
- Please do not use this device when people, especially children, or pets are nearby. Direct them away from the working area.
- The operator or the user are responsible for possible accidents or damage to other persons or to their property.
- Do not wear loose clothing or jewellery as this can get caught in the machinery as it runs.
- Use safety equipment. Wear protective gear such as an anti-dust mask, non-slip safety shoes, a helmet or hearing protection.
- Stay vigilant, watch what you are doing and show good sense when you use the generator. Do not use if you are tired or under the influence of drugs, alcohol or medicines.
- Install the generator in a place that is well ventilated and make sure that there is at least 1.5 metres between the generator and the walls of the building or other equipment. Do not place flammable liquids or gases near the generator.
- Do not run the generator in an enclosed or badly-ventilated space. The exhaust gas from the motor contains carbon monoxide which is toxic and may lead to a loss of consciousness or death.
- Run the generator in respect of the power indicated in the user's manual. Do not run the generator with an overload or at excessive speed.
- The silencer of the generator becomes extremely hot when the motor runs or even for a time after it has stopped. Do not touch it as it will burn you.
- Do not transport or move the generator until it has cooled down.
- Perform periodic maintenance and resolve problems that appear immediately. Do not run the generator before correcting any fault detected.
- The generator uses a system of air-cooling, and it is necessary to clean its components regularly, including the grilles, the cover of the fan and the fan itself so as to ensure cooling.

- Keep the fuel filter clean, and change the oil of the motor regularly.
- Periodically check the installation of the connections and the tightness of the fixations, re-tightening them if necessary.
- Clean the components of the air filter periodically, and replace the air filter when necessary.
- Remove any electrical equipment that is plugged in before starting or stopping the generator.
- Before transporting the generator, you must empty the fuel tank.
- Maintenance and repair of the generator must be carried out by a qualified technician from an authorised after-sales service centre.

 **WARNING:** when you start the generator with the cord, watch out for sudden changes in the rotation of the motor!!! Risk of wounding!!! Never cover the generator when it is running. The cut-out mounted on the generator has the aim of reducing the risk of electric shock. If it needs to be replaced with another cut-out, the latter must correspond to the technical specifications of the generator. Due to important mechanical constraints, it is necessary to use a flexible sheathed cable with a strong rubber protective layer (conforming to IEC 245-4) or a similar cable. If using an electrical extension cable, the total length of the extension must not exceed 60m when the section of the wire is 1.5mm² and must not exceed 100m when the section of the wire is 2.5mm².

Additional requirements for low-power generating sets for use by laymen

- Protect children by keeping them at a safe distance from the generating set.
- Fuel is combustible and easily ignited. Do not refuel during operation. Do not refuel while smoking or near naked flames. Do not spill fuel.
- Some parts of the internal combustion engine are hot and may cause burns. Pay attention to the warnings on the generating set.
- Engine exhaust gases are toxic. Do not operate the generating set in unventilated rooms. When installed in ventilated rooms, additional requirements for fire and explosion protection shall be observed.
- Before use, the generating set and its electrical equipment (including lines and plug connections) should be checked to ensure that they are not defective.
- Protection against electrical shock depends on circuit breakers specially matched to the generating set. If the circuit breakers require replacement, they should be replaced with a circuit breaker having identical ratings and performances characteristics.
- Due to high mechanical stresses, only tough rubber-sheathed flexible cable (in accordance with IEC 60245-4) or the equivalent should be used.
- The user shall conform to regulations of electrical safety applicable to the place where the generating sets are used.
- The user must respect the requirements and precautions in the case of resupply by generating sets of an installation, depending on existing protective measures in this installation and applicable regulations.
- Generating sets should only be loaded up to their rated power under the rated ambient conditions.
- Prior to commencing maintenance work it shall be ensured that untimely start-up is not possible.

Security measures when filling the fuel tank

- The fuel is extremely flammable and poisonous.
- This generator only uses petrol (gasoline); any other kind of fuel will damage the motor.
- Do not overfill the tank with petrol to avoid spilling. If you notice a spill, it must be wiped up completely with a dry cloth before starting the motor.
- If you swallow fuel by mistake, if you inhale fuel vapours or if you get drops of fuel in your eyes, see a doctor immediately. If a certain quantity of fuel is spilt on your skin or clothing, wash or change your clothes.

- Always stop the motor of the generator when filling it with fuel.
- Never fill the fuel tank while smoking or near a naked flame.
- Make sure you don't spill fuel on the motor and the exhaust grille of the generator during filling with fuel.
- Keep the fuel in an appropriate recipient and sheltered from any sources of fire.
- Carry out filling in a safe place, and slowly open the fuel cap to release the pressure which has built up inside the tank. Wipe up any drops of petrol that have spilled before starting the motor.
- To prevent fire, move the generator at least 4 metres away from the area for filling with fuel.
- Make sure that the fuel cap is tightly closed before starting.
- Do not keep petrol in the tank for a long time.
- While using or transporting the generator, make sure you keep the generator upright, otherwise the fuel may escape from the carburettor or the fuel tank.

Electrical safety

Before each use ensure that the load to be connected does not exceed the power of the current produced by the generator.

To avoid electric shock, you must follow the following instructions:

- Do not touch the generator with wet hands.
- Do not run the generator under rain or snow.
- Do not run the generator near water.
- Connect the generator to earth. Use a sufficiently thick conductor for the earth wire.
- Do not operate the generator in parallel with another generator.
- If using electrical extensions, make sure that they are sufficiently thick to transport the current and that they are used correctly.



The connection of a generator used for auxiliary power to the electrical installation of a building must be performed by a qualified electrician, and in conformity to the provisions of the applicable laws and norms in the field of electricity. Incorrect connections will cause leakage of the current from the generator into the lines of the public electricity company. Such leakage could electrocute the workers of the public electricity company working on the network or other persons in contact with the line during a power cut. Also, when the public power supply is re-established, the generator can explode, catch fire or generate fires in the building's electrical installation.

















Before connecting electrical devices to the generator, make sure that their voltage specifications and frequency of functioning correspond to the technical characteristics of the generator. There may be damage if the device connected is not designed to function with a voltage tolerance of +/- 10% or a frequency tolerance of +/- 3 % compared with those of the generator.

Protection of the environment

- You must periodically check the silencer (Before doing this, switch off the generator and let it cool completely). A damaged silencer increases noise.
- Do not throw motor oil into the drains but deposit it at a collection point set up for that purpose.
- The fuel for this machine is combustible and explosive. After stopping the machine, you must handle the remaining fuel correctly and meet local environmental requirements.
- To dispose of residual fluids, proceed as follows:
 - Close the fuel tap
 - Drain fuel from the fuel tank
 - Empty carburettor fuel

Symbol

	Attention!
	Please read the manual carefully before using the unit!
	Conforms to relevant safety standards
	Do not dispose of old appliances with domestic rubbish .
	Guaranteed sound power level
	Ground connection
	Fill in engine oil
	It is forbidden to run the generator in an enclosed room because exhaust emissions can lead humans or animals to coma to death.
	This symbol indicates the surface is very hot and not touching
	Keep away from the machine
	Exhaust emissions are harmful to health of body
	No naked fire near the machine!
	Do not connect with the electricity system.
	Danger ! Electrical shock !
	No fire when refueling

2. QUICK START

WARNING

- ◆ Only use outdoors. The generator emits carbon monoxide, a toxic colorless and odorless gas that can cause death or serious injury.
- ◆ Ensure that the generator is placed horizontally.
- ◆ Never work in the rain, snow or other humid environment.
- ◆ Turn off the generator and avoid cigarettes, sparks, fire or explosion while refueling.

Check before start

- Remove the oil access door, unscrew the dipstick to check the oil level. If oil level is below the bottom of the dipstick, add recommended oil (capacity: 1.1L). Use a strong detergency, four-stroke engine oil and choose proper viscosity of the oil according to your area's average temperature.
- Remove the maintenance cover, connect the start cable and the battery cable, make sure the connect is firm.

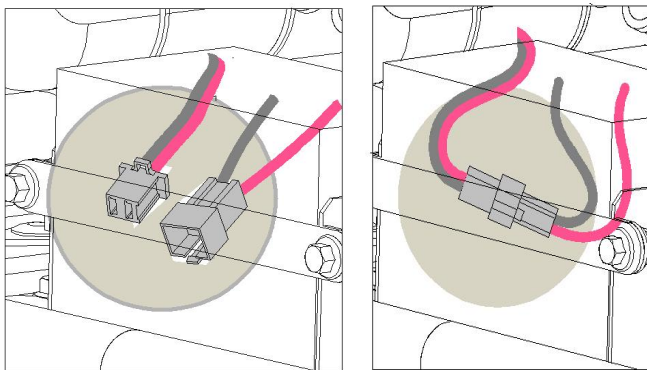

- Connect the DC charging wire (you can find it in the generator accessories bag) to the DC socket on the generator control panel, check the battery voltage with a multimeter to see whether the battery is losing electricity (Standard voltage: 12V-13.5V. If the battery voltage is too low, please recharge it with the battery charger).
- Charge for 3 hours, or until full, disconnect the battery charger.
- Unscrew the fuel tank cap to add gasoline to the fuel tank. Please use unleaded petrol or gasoline above #87. Do not add gasoline too fast to avoid gasoline spill. Prevent any dirt, dust or water from entering the tank. Screw the fuel tank cap tightly after finish.

Be careful

- ◆ Do not use two-stroke gasoline or dirty gasoline.

Start the generator

1. Start the generator in the following way.

Recoil start:

- Turn the fuel switch to start position.
- Pull outward the choke cable.
- Insert the ignition key and turn to "ON" position.
- Gently pull the handle until you feel resistance, then quickly pull the handle to start the generator.
- According to the ambient temperature, push the choke cable inward after the starting the generator. The lower the ambient temperature is, the slower the inward pushing is. The higher the ambient temperature is, the faster the inward pushing speed is. Make sure the engine does not turn off when pushing inwards.

Electric start:

- Turn the fuel switch to start.
 - Pull outward the choke cable.
 - Insert the ignition key and turn to "ON" position.
 - Turn the ignition key to "START" position, do not loosen until the generator is started. Turn the key no more than 10 seconds. If fail to start, loosen the key and wait 10 seconds to try one more time.
 - According to the ambient temperature, push the choke cable inward after the starting the generator. The lower the ambient temperature is, the slower the inward pushing is. The higher the ambient temperature is, the faster the inward pushing speed is. Make sure the engine does not turn off when pushing inwards.
2. When the output indicator lights on the control panel is on, the generator can be used. Before connecting any load, the generator should be grounded. Please use a thick cable to the ground terminal on the generator control panel is connected to an external ground source.
 3. Make sure all equipment is turned off and the switch in order to ensure that the equipment is intact, confirm the use of electrical appliances does not exceed the total power rating of the generator.
 4. Connect your device to a suitable outlet generator control panel.

Turn off Generator



Note

- ◆ Turn the ignition key to "OFF" position, the generator will stop immediately in any condition.

1. Turn off the generator in the following instructions.
 - Turn off and unplug the connected equipment.
 - Turn the ignition key to "OFF" position to stop the generator.
 - Turn off the fuel switch.

When not using the generator for a long time, please turn off the generator.

Foreword

Thank you for purchasing our Inverter generator

This manual includes the operation and maintenance of Model FGH17000ES series inverter generator. All contents of this manual are consistent with the latest products (when this manual is printed).

Our company reserves the right to make changes without notice and without any liability.

This manual is owned by BUILDER SAS and is not allowed to be recorded without written permission. This manual should be considered as a permanent part of the generator and should be kept with it if the generator is resold.

Please pay special attention to the following text:

WARNING

This symbol is displayed if you do not follow the correct operation of the manual, it will lead to serious personal injury and other accidents..

If you have any questions about the generator, please contact your dealer.

BE CAUTIOUS

As long as following the instructions in this manual, the generators are safe and reliable. Be sure to

read and understand the instructions before use, otherwise incorrect operation could result in personal injury or equipment damage.

3. SAFETY LABEL POSITION

These decals indicate serious accident that you may cause.

Please read the decals, safety precautions and precautions mentioned in this manual carefully.

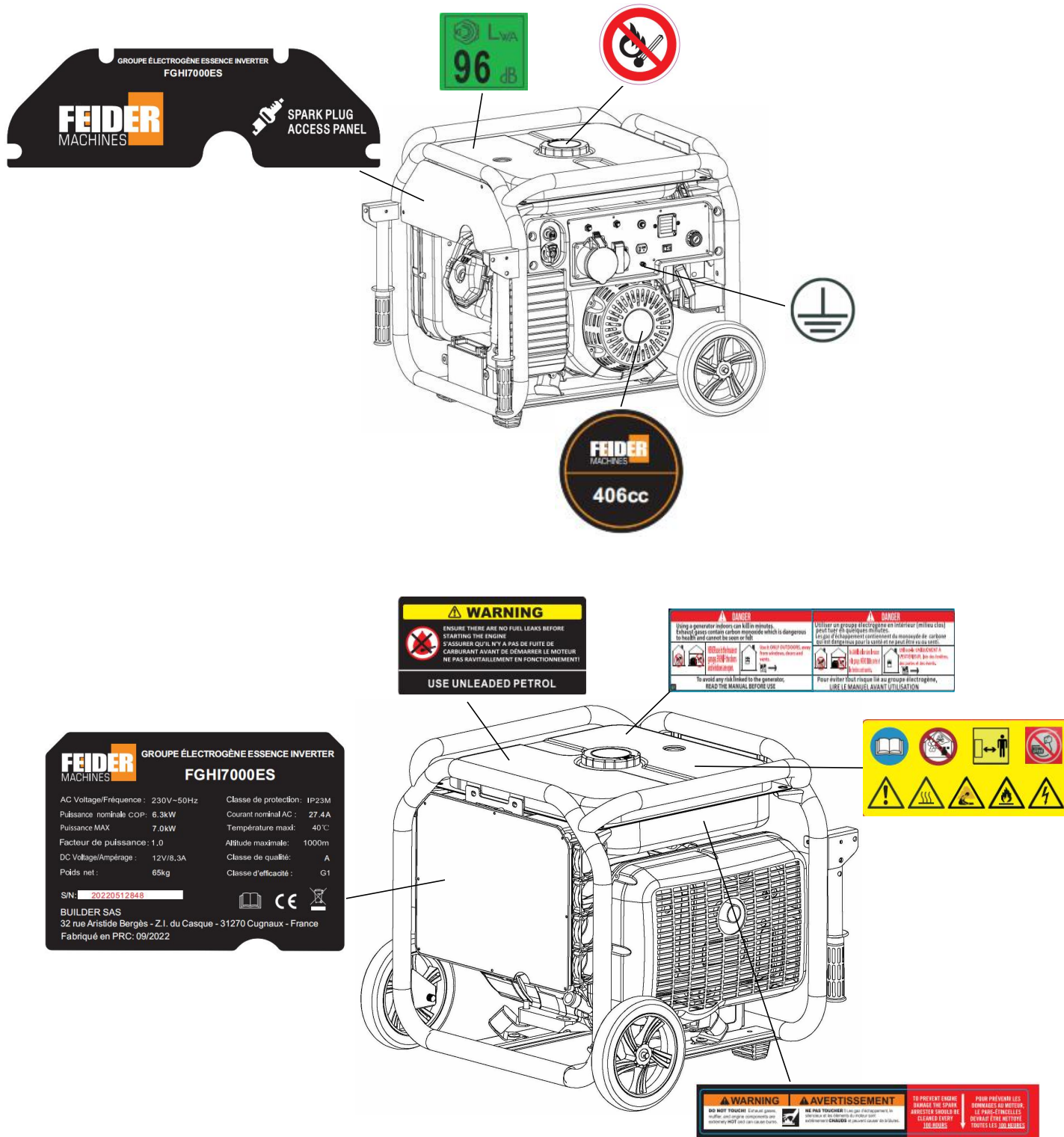

4. PARTS IDENTIFICATION

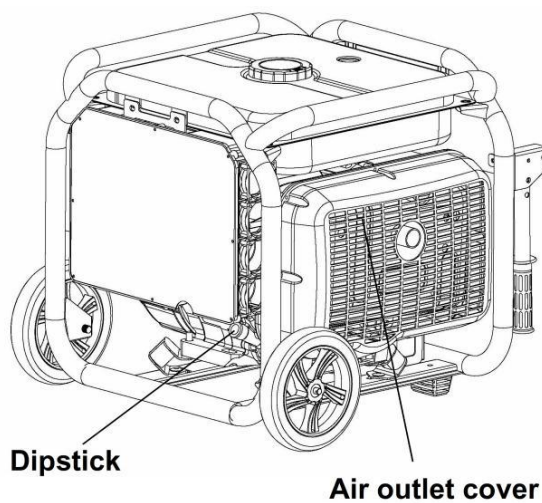
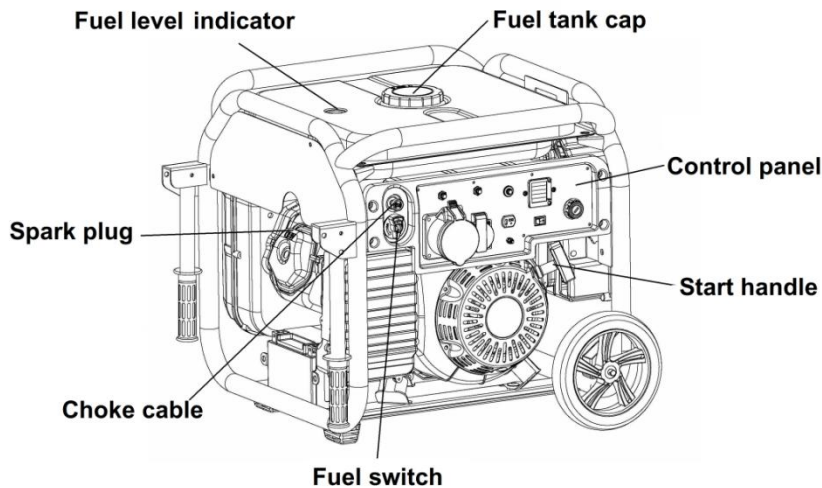

Control Panel

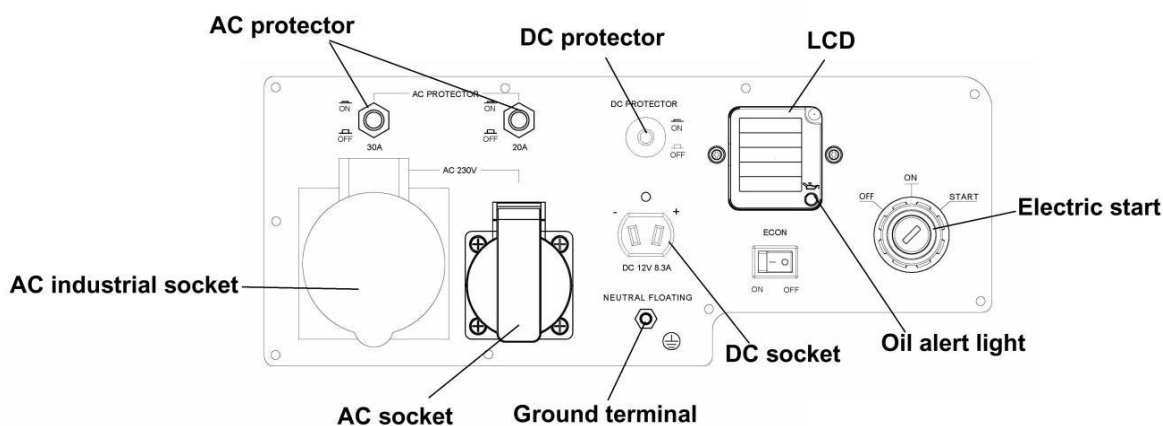

5. CHECK BEFORE OPERATION

The generator should be placed on a flat ground, without debris around, and at least 1 meter away from buildings and other equipment.



BE CAUTIOUS

- ◆ Be sure to check whether the generator is placed horizontally, and the engine is off.

Check the Oil Level



BE CAUTIOUS

- ◆ Use non-detergency oil or 2-stroke engine oil could shorten the engine life.
- ◆ Use a strong detergency, high-quality 4-stroke engine oil, which must meet or exceed US automobile manufacturer's requirements of the American Petroleum Institute classification SG, SF levels.
- ◆ Choose the appropriate oil that the viscosity is suitable for the average temperature of your area.

SEA viscosity grade as follows:

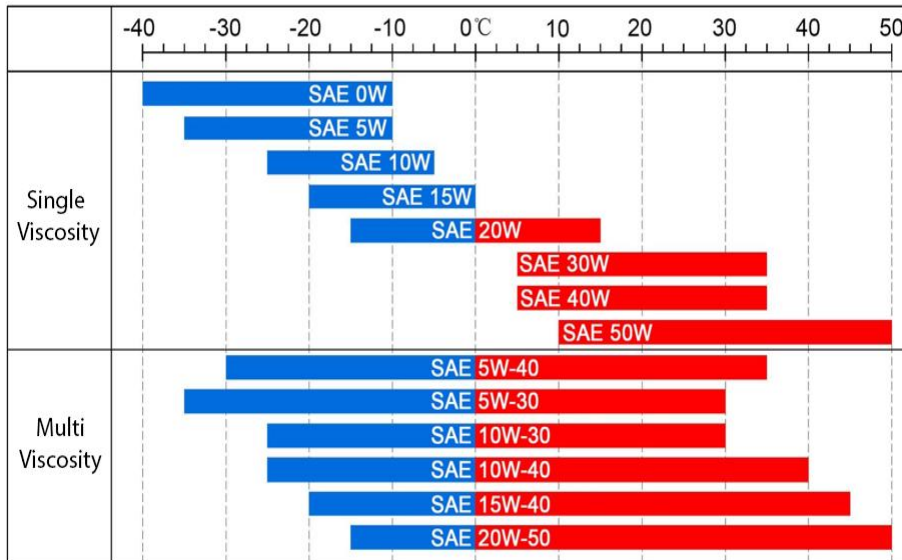

Loosen the screw on the side maintenance cover to remove the cover.

Remove the oil dipstick, wipe the dipstick with a clean cloth, insert it into the oil port without tightening the dipstick to check the oil level.

If the oil level is below the bottom of the dipstick, add the recommended oil.



BE CAUTIOUS

- ◆ Operation of the engine with insufficient engine oil may cause serious damage to the engine.
- ◆ The oil alert system automatically shuts down the engine before the oil level drops to safety line. To avoid the accidentally shutdown, we recommend that you check the oil level regularly.

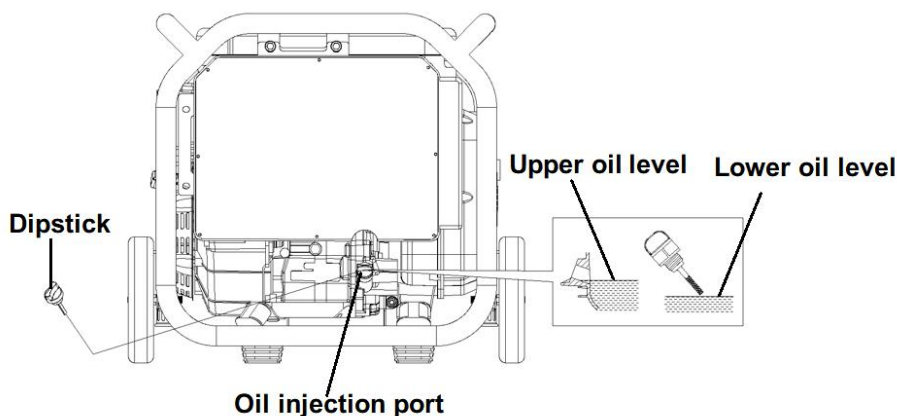

Check the Fuel Level

Use automotive gasoline (preferably unleaded or low-lead gasoline to reduce combustion chamber carbon and reduce environmental pollution).

When the fuel level is too low, please add fuel to the required level.

Never use a mixture of oil and gasoline or dirty gasoline.

Prevent dirt, water into the fuel tank.

Tighten the fuel cap after refueling..

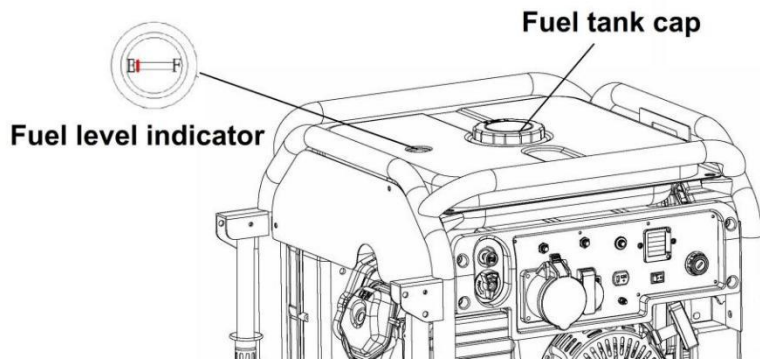

WARNING

- ◆ Gasoline is extremely flammable and explosive under certain conditions.
- ◆ Please refuel in the ventilated place and turn off the engine when refueling. Generator refueling area and gasoline storage area is strictly prohibited smoking and lighting fires.
- ◆ **Never add fuel when the generator is running. EXTREMELY DANGEROUS!**
- ◆ Do not overflow the fuel tank (no fuel above the neck). Tighten the fuel tank cap after refueling.
- ◆ BE careful not to spill fuel when refueling, due to spilled fuel or oil mist may catch fire. If there is a fuel spill, make sure that the fuel is evaporated completely before the engine starts.
- ◆ Avoid prolonged, repeated exposure to gasoline or inhale mist. Do not let children touch.

Check the Air Filter

Check the air filter core to make sure it's clean and the performance is as normal.

- Remove the air filter cover screws and remove the air filter cover.
- Draw the air filter box drawer as shown below.
- Pull out the drawer, check the air filter and, if necessary, clean or replace the filter sponge.
- Clean or replace the filter and then follow the opposite action to install the air filter.

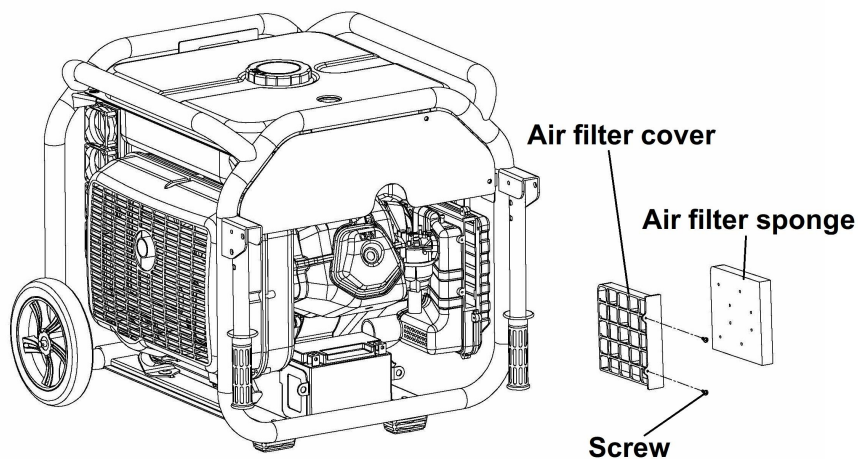



BE CAUTIOUS

- ◆ Never run the engine without a filter, or dirt will enter the engine through the carburetor and cause rapid wear of the engine.

It is normal if you find little oil under air filter box, please clean it after use (when the machine is entirely stopped).

Connect the Battery

The battery inside the generator is disconnected. Connect the battery before you start the generator.



NOTICE

- ◆ Due to the characteristics of the lead-acid battery, it may require you to charge it after the first use or long-term storage. It is recommended that connect the battery charger to the DC socket on control panel for charging. If the battery does not have enough voltage, the generator will not be able to use the electric start or remote start. You can only use the recoil start to start the engine.

- Loosen the screw on battery cover and remove the cover.
- Connect the battery cable to the generator start cable.
- Reinstall the battery cover.

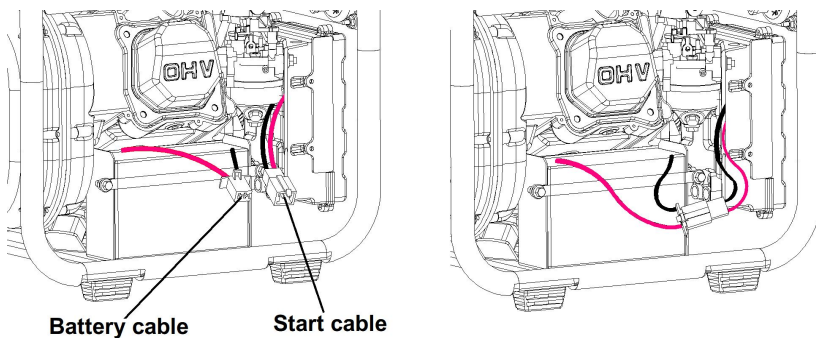

6. START THE ENGINE



NOTICE

- ◆ You can recoil start or electric start the engine.
- ◆ For Electric Start, you can just turn the ignition key to “OFF” to shut off the generator.
- ◆ If the battery power is too low, you can still start the generator by using recoil start, but you cannot start the generator using the electrical start. You must charge the battery, or start the generator by recoil start, so that the generator can run as normal and self-charge the battery.

Recoil Start

Disconnect the load from the socket before starting the generator

- Turn the fuel switch to “ON” position.

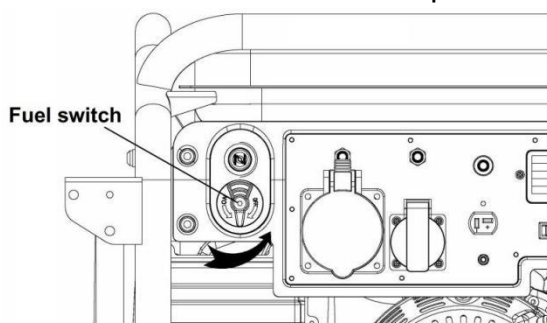

- Pull outward the choke cable.

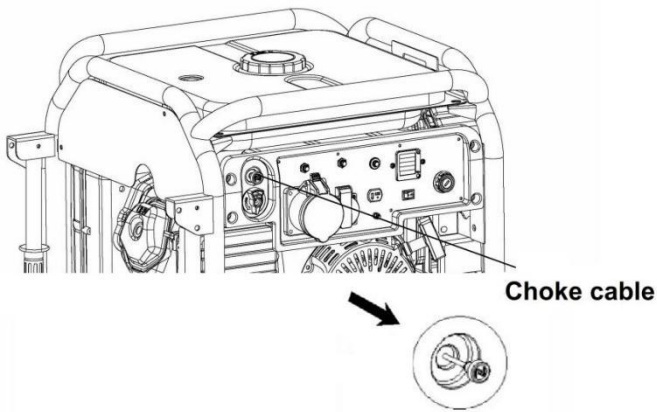

- Pull the handle until you feel resistance, then pull the handle outward to start the generator.
- According to the ambient temperature, push the choke cable inward after starting the generator. The lower the ambient temperature is, the slower the inward pushing is. The higher the ambient temperature is, the faster the inward pushing speed is. Make sure the engine does not turn off when pushing inwards.

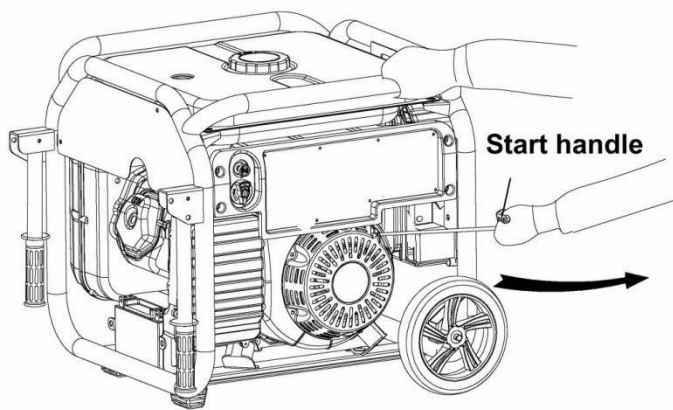

BE CAUTIOUS

- ◆ Never allow the starting handle to rebound. Slowly put it back.
- ◆ When pulling the cable, hold the generator tightly to prevent the generator from overturning.

Electric Start

- Turn on the Fuel switch.
- Pull outward the choke cable
- Turn the key to "ON" position
- Turn the ignition key to the "START" position until the generator is running. Hold the key for up to 10 seconds. If fail to start for the first time, release the key and wait 2 seconds for another try.
- After starting the generator, push the choke cable inward.

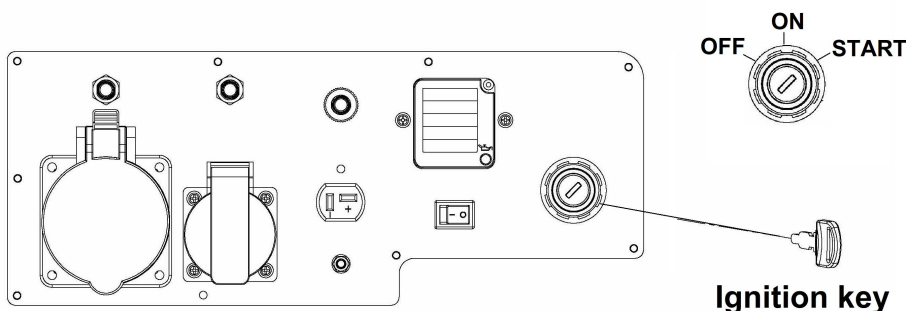

Working at high altitudes

In high altitude areas, the air-fuel mix in a standard carburetor is relatively thick, so the engine operating performance will reduce, while the fuel consumption increases. At this point you can adjust the main jet on the carburetor (smaller), while adjusting the ratio-mixing screw, then you can change the performance of the engine in high altitude areas. If you are always using the generator at an altitude of 1500 meters or above, please let a BUILDER SAS authorized agent modify the carburetor.

Even with the appropriate main jet, the engine power will still drop by 3.5% as altitude increases every 305 meters. If you do not make these adjustments, the impact of altitude on the power will be greater.



BE CAUTIOUS

- ◆ If the main jet is designed for high altitude areas but is operating at low altitudes, it may cause decreased output power, overheating, or serious engine damage due to thin air-fuel mix.

7. OPERATING THE GENERATOR



WARNING

- ◆ In order to prevent electric shock caused by improper use, the generator should be grounded. Connect a thick cable between the ground terminal of the generator and the external ground source.
- ◆ If the unit is used as a backup power source for a building, the connection of the generator to its power system shall be carried out by a professional electrician and must comply with the applicable laws and regulations. Otherwise, the power of the generator may impact on the public circuit. If the power company employees or others touch the wire in the meantime, it will lead to injury or even death; At the same time, due to the impact of electricity, the generator may explode, burn or cause the building electricity equipment to fire.



BE CAUTIOUS

- ◆ When the generator is running continuously, do not exceed the rated power. In other cases, pay attention to the total power of the connected equipment.
- ◆ Do not exceed the rated current of the socket.
- ◆ Do not use the generator for purposes that it cannot achieve. Please also observe the following requirements:
 - Do not parallel generators with unauthorized units or use unauthorized parallel power cables or boxes.
 - Do not extend the exhaust pipe
- ◆ If a longer cable is required, use a flexible cable for with rubber sleeve (the cable should comply with IEC standards).
- ◆ The length of the extension cable is limited, the cable of 2mm² is 60 meters long; the cable of 3mm² is 100 meters long.
- ◆ The generator should be away from other electric wires or cables, such as: electricity transmission network.



Note

- ◆ When using AC power, you can use DC power at the same time. Please pay attention to the sum of the power of AC and DC. It cannot exceed the rated power of the generator.

Use of AC Power

- Connect the ground bolt.

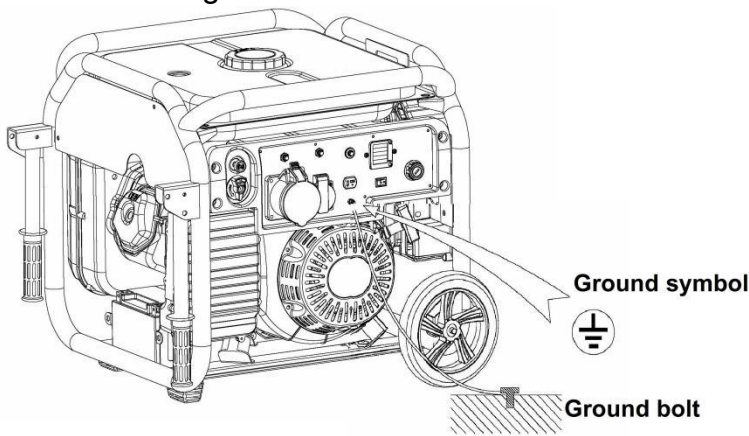

- Start the engine in accordance with the “Start the Engine” requirements.
- Make sure the connected device is turned off, then connect the device to the generator.
- When the LCD is on, turn on the connected device.

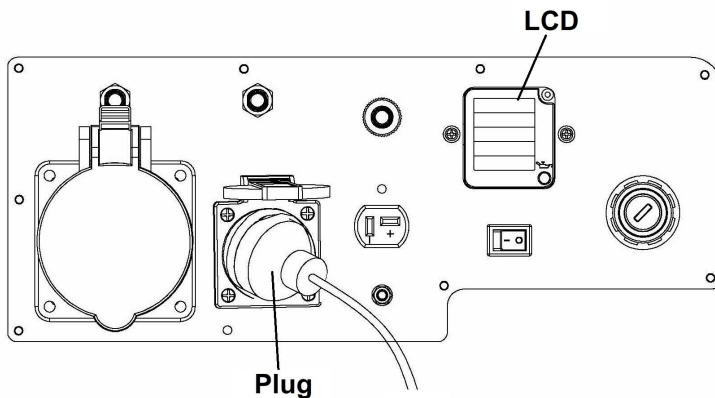

BE CAUTIOUS

- ◆ If the connected device is not turned off before you start the generator, it will start suddenly, resulting in personal injury.

LCD and Oil alert indicator

The LCD lights up after you start the generator.

If the generator is overloading or the connected device is internally faulty, the LCD displays “Overload”, and there will be no power output. You must shut the generator off to stop the generator.

During the normal operation of the generator, the LCD will display the current output status in real time.

If the generator is overloading or the connected device is internally faulty, the LCD will display “0” instead of the status of the generator on Voltage, Current or Frequency, and the Power column will display “OVER”.

If the LCD displays “Overload”, the generator will not stop automatically at this time. Please unplug the connected device from the generator, turn off the device, check the device and the connecting cable, confirm the cause of the overload. After you find out the cause of the overload and confirm

that the problem has been resolved, press the Reset Button on the control panel. After 3 seconds the LCD turns normal and the generator will start operating normally.

If you press the Reset Button, wait 3 seconds and the LCD doesn't turn normal, please turn off the generator and contact the authorized dealer.

If the oil alarm indicator is on, the engine will automatically shut down. Please check whether the oil should be added.

NOTICE

- ◆ Before connecting the device to the generator, check whether the equipment is in good condition and whether the required power exceeds the limit of the generator. Then start the generator and connect the device.
- ◆ Make sure the device is turned off before connecting to the generator.

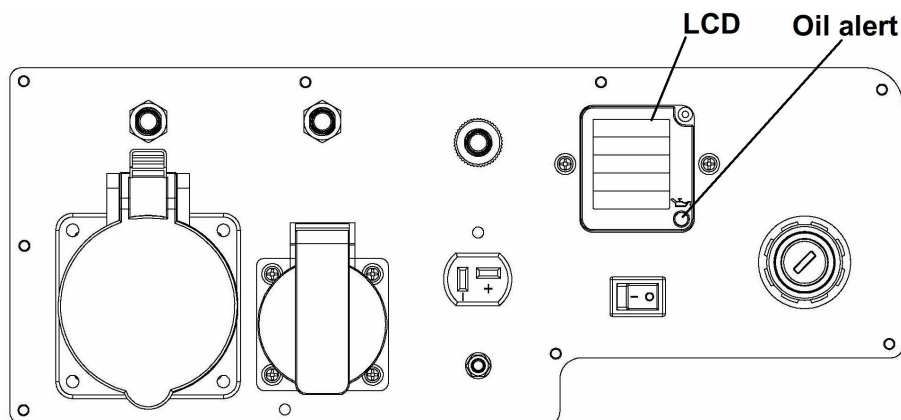

When using the generator with a pure inductive load, the pure inductive load cannot exceed the rated power of the generator. The power can only run 40% to 75% of rated power on pure inductive load.

Model		FGHI7000ES
Rated Power (W)		6300
Frequency (Hz)		50
Power Factor (cosΦ)		1.0
AC	Resistive Load 100%	0-6300W
	Inductive Load 40%~75%	0-2520W~4725W
DC		100W(12V\8.3A)

Rated Power Output Conditions of the Generator

Altitude: 0 meter; Ambient temperature: 25°C; Relative humidity:30%

Only in the specified cooling and ambient temperature, the generator can be loaded to the rated power. If the operating conditions do not meet the requirements of the standard, or the generator or engine cooling is poor (in a limited area), then the generator power should be reduced.

Ambient temperature coefficient: °C (Relative humidity 30%)

Altitude (m)	Ambient temperature (°C)				
	25	30	35	40	45
0	1	0.98	0.96	0.93	0.90
500	0.93	0.88	0.83	0.78	0.73
1000	0.87	0.82	0.77	0.72	0.67
2000	0.75	0.70	0.65	0.60	0.55
3000	0.64	0.59	0.54	0.49	0.44
4000	0.54	0.49	0.44	0.39	0.34

Note:

When the relative humidity is 60%, the ambient temperature improvement factor is C-0.01

When the relative humidity is 80%, the ambient temperature improvement factor is C-0.02

When the relative humidity is 90%, the ambient temperature improvement factor is C-0.03

When the relative humidity is 100%, the ambient temperature improvement factor is C-0.04

For example:

When the rated power of the generator is $P_N = 6.3\text{KW}$, the altitude is 1000m, the ambient temperature is 35°C , the relative humidity is 80%. Under these circumstances, the rated output of the generator is $P = P_N \times (C - 0.02) = 6.3 \times (0.77 - 0.02) = 4.725\text{KW}$.

Use of DC Power

DC socket only supplies for 12V automatic battery charging.



NOTICE

- ◆ When using a DC socket to charge the battery, the person must be present to monitor the battery voltage. If the battery voltage exceeds 16V, the charge must be stopped immediately, otherwise the battery burns or explodes.

- Start the generator as the above instruction.
- Connect the charging cable to the generator DC socket and connect it to the battery terminal

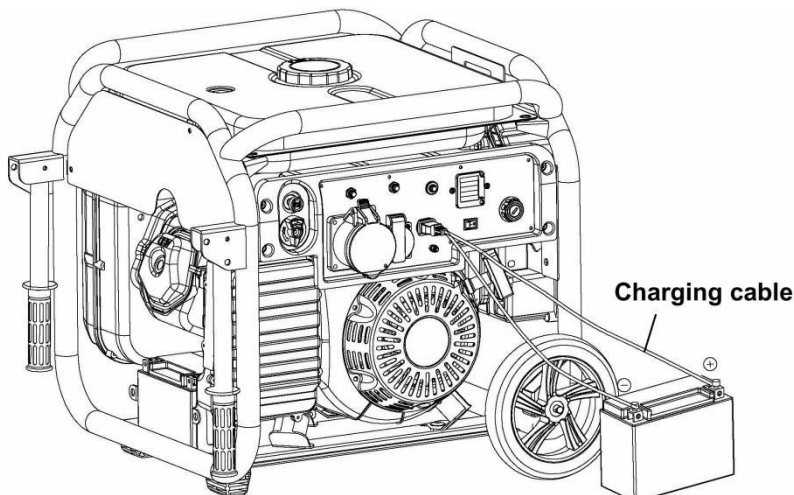

WARNING

- ◆ Connect the charging cable to the battery first, and then connect it to the generator. Disassembly must start from the generator side, which prevents sparks start beside the battery.
- ◆ When connecting the charging cable to the car battery, disconnect the battery ground wire first. Remove the cable and then connect to the ground wire on battery after charging is complete. So that even if you make the battery terminal contact with the car frame by accident, it can prevent short circuit or spark.



WARNING

- ◆ Do not start the car when the generator is connected to the battery, otherwise it might damage the generator.
- ◆ Charging cable should be properly connected to the positive and negative terminals of the battery, otherwise it will damage the generator or the battery.



WARNING

- ◆ Charge should be properly ventilated, and away from fireworks, because the battery will evaporate flammable gas.
- ◆ The battery contains sulfuric acid (electrolyte). Contact with skin or eyes can cause burns. Wear protective clothing and mask.
- ◆ Electrolyte is toxic, if the electrolyte splashed on the skin, immediately rinse with water.
- ◆ If the electrolyte splashes into the eyes, rinse immediately with water for 15 minutes and seek medical care.
- ◆ If you accidentally swallow the electrolyte, drink plenty of water or milk immediately, and then drink milk or vegetable oil with magnesium oxide and seek medical care.
- ◆ Batteries and electrolytes should be placed where children are not accessible.

DC protector

When using AC power, you can use DC output at the same time .

The DC circuit overload may cause DC protection. And the switch should be reset.

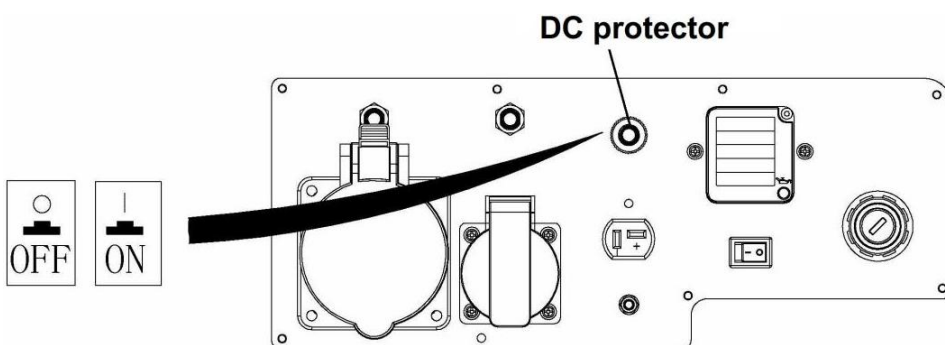

Oil alert system

The oil alert system is designed to prevent damage to the engine due to insufficient oil. The oil alarm system automatically shuts down the engine before the oil in the crankcase drops to the safety line (although the start switch remains in the "on" position).

After the engine alarm system shuts down the engine, if the user tries to start the engine again, the oil alert indicator (red) will flash briefly and the engine will no longer operate. Please check the oil level regularly.

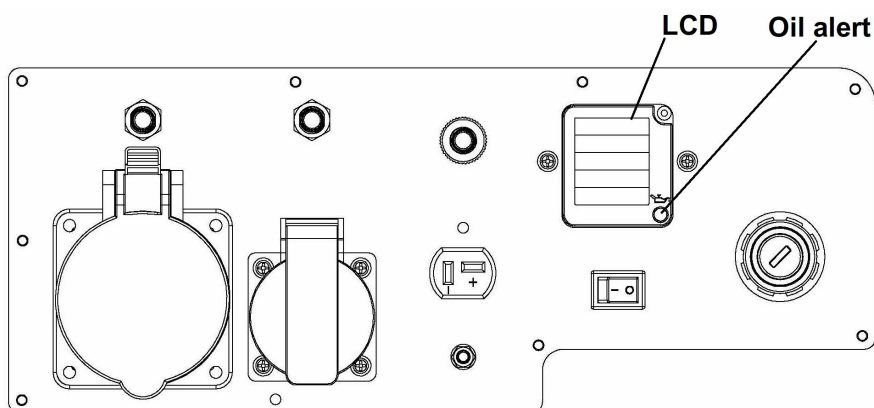

8. SHUT OFF THE ENGINE

If you need to shutdown the engine urgently, turn the start switch to the 'OFF' position.

For Electric Start mode: you can turn the power switch to "OFF" position to stop the generator.

- Shut off all the connected devices, pull out the plugs.

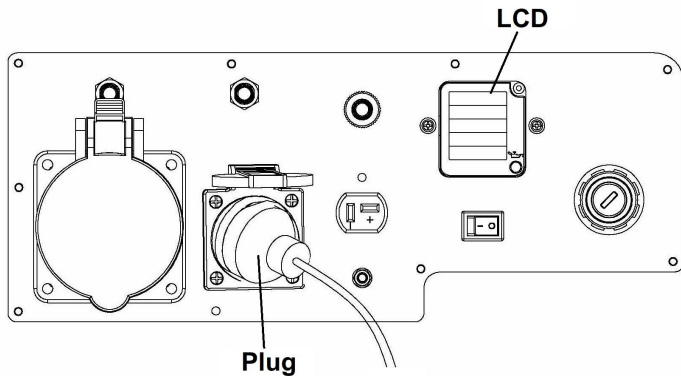

- Turn the ignition key to "STOP" position (turn the engine switch to the 'OFF' position for recoil start).

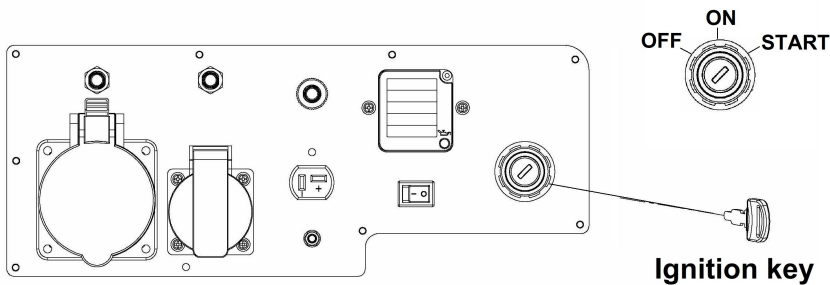

- Turn the fuel switch to "OFF" position.

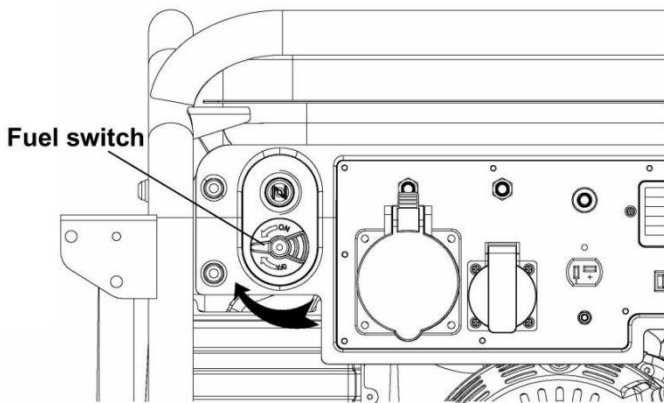

When not using the generator for a long time, please turn off the generator.

9. MAINTENANCE

Maintenance and adjustment schedules are developed to keep the generator in the best working condition.



WARNING

- ◆ Turn off the engine before any maintenance. If the engine must be operated during maintenance, be sure to operate it in a ventilated area because the exhaust contains toxic carbon monoxide.



NOTICE

- ◆ Please use authorized spare parts. The use of inferior parts will damage the engine.

Maintenance schedule

Please do the maintenance within the specified month or hour.

Project	Periodic maintenance time (1)	Each use	Per month or 20 hours	Every 3 months or 50 hours	Every 6 months or 100 hours	Per year or 300 hours
Engine oil	an examination	○				
	Replace		○			
Air filter	an examination	○				
	Clean			○ (2)		
Muffler Anti-Fire	an examination	○				
	Clean		○			
Spark plug	Cleaning-Adjustment				○	
Fuel sediment bowl	Clean				○	
Lash	Cleaning-Adjustment					○ (3)
Fuel tank and filter	Clean					○ (3)
Fuel line	an examination	Every two years [If necessary, change (3)]				

Note:

- Normal maintenance interval;
- In areas where pollution is severe, check and repair frequently.
- The above regular maintenance schedule is calculated at ambient temperature of 25°C. If the ambient temperature exceeds 30°C, reduce the load power of the generator or shorten the time interval for replacing the oil (choose one operation).

Oil Change

When the engine is warm, you can quickly and completely discharge the oil.



BE CAUTIOUS

- ◆ Make sure that the engine switch and the fuel switch are off before draining the oil.

- Loosen the oil drain screw, drain the oil.
- Install the oil drain tube.
- Fill the recommended oil, check the oil level.
- After filling a new oil, shake the generator about a few times to ensure that the float of the oil alarm system works properly.

Oil capacity: 1.1L

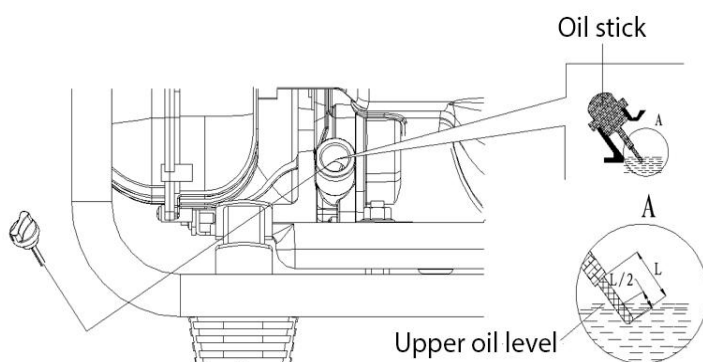

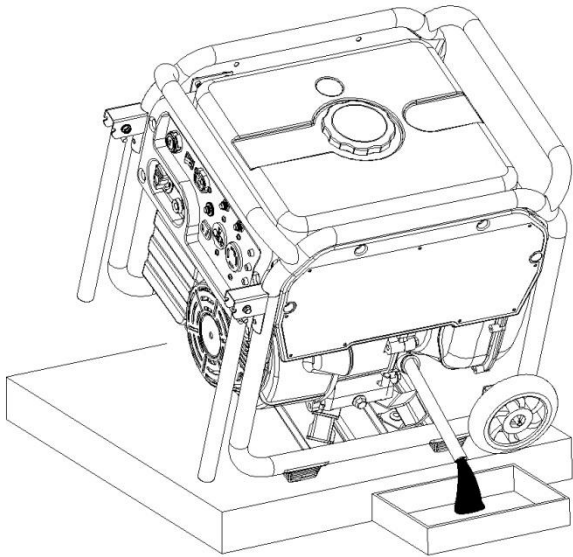

Wash your hands with soap and water after you touch the oil.



BE CAUTIOUS

- ◆ In order to comply with environmental requirements, we recommend that collect the waste oil into a sealed container, send to the local service station or recycling center near your location. Do not spill the oil on the ground or garbage.

Maintenance of air filter

The dirty air filter will block the air into the carburetor. To prevent the carburetor from malfunctioning, check the air filter following the maintenance schedule. If you use the generator in a particularly dirty place, you need to keep the maintenance regularly.



WARNING

- ◆ Do not use gasoline or low-ignition solvents to clean the generators because they are flammable and explosive under certain conditions.

Check the air filter core to make sure it's clean and the performance is normal.

- Remove the side maintenance cover screws, open the side maintenance cover.
- Remove the three screws on the air filter box.
- Pull out the air filter drawer as shown by the arrow below.
- Pull out the air filter drawer, check the air filter sponge, and if necessary, clean or replace the filter.
- Clean or replace the filter and then follow the opposite action to install the air filter back.

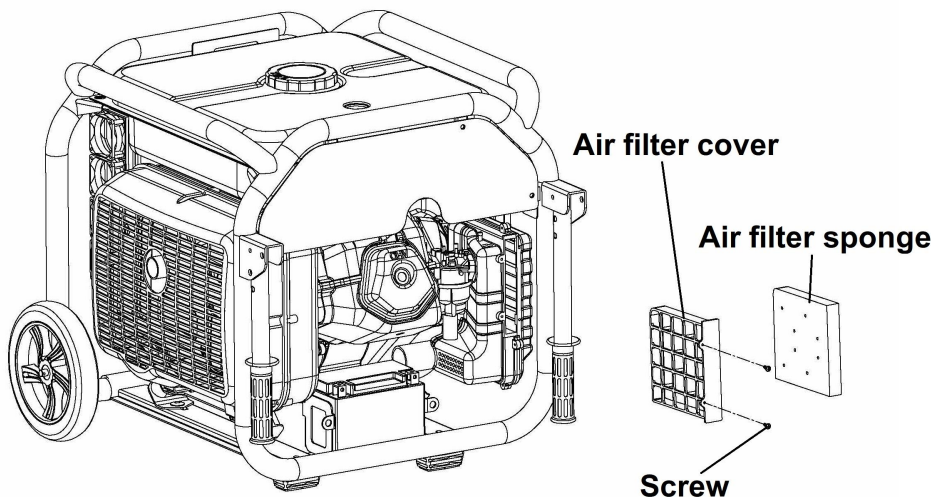

Maintenance of Spark Plug

Use recommended spark plug (NGK F7RTC):

In order to ensure the best operation of the engine, the spark plug clearance must be appropriate.

- Remove the top maintenance cover screws and remove the top maintenance cover plate.
- Pull the ignition coil out.
- Remove the spark plug with a spark plug removal tool.

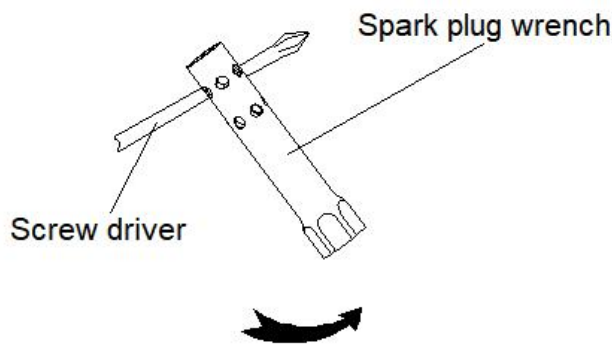
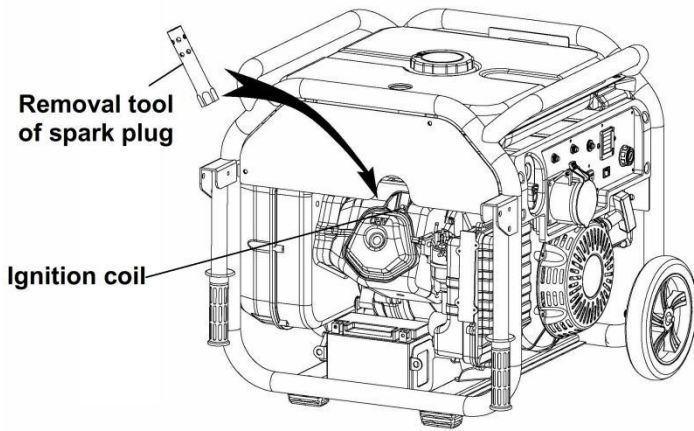

Insert a screwdriver into the hole of spark plug socket handle, unscrew the spark plug and take it out.

- If the insulator has been ruptured, it must be scrapped. If you want to use the spark plug again, use a brush to clean the spark plug.
- Measure the spark plug clearance with a feeler gauge, and the spark plug clearance should be 0.6-0.7mm (0.024-0.028 in)
- Install the spark plug carefully. Be careful of the thread dislocation.
- After installing a new spark plug, tighten it about 1/2 turn around with a wrench and press the gasket back. If it is a used spark plug that still works well after inspection, tighten it with a wrench about 1/4 to 1/8 turn around with a wrench after relocating
- Reinstall the ignition coil.

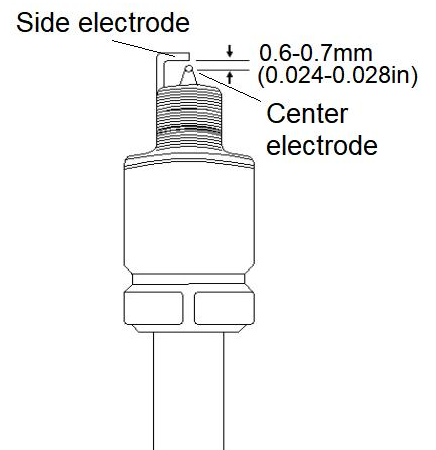

BE CAUTIOUS

- ◆ The spark plug must be firmly installed, otherwise the spark plug will become too hot and damage the generator
- ◆ Do not use the spark plug with different heat value.

Maintenance of Muffler & Fireproof Net

Dirty muffler will affect the effect of the generator and the power of the engine. To ensure the normal operation of the generator, please clean up the muffler fireproof net regularly. If you use the generator in a particularly dirty place, you need to clean it up frequently. Replace the muffler fireproof net if necessary.



BE CAUTIOUS

- ◆ You must shut off the generator to clean the muffler fireproof net.
- ◆ Make sure the engine is shut down, otherwise the high-temperature muffler might cause burns.

- Remove the outlet cover plate screws, open the outlet cover plate.
- Remove 2 screws on the muffler fireproof net.
- Remove the muffler fireproof net as the direction on the picture followed.
- Take out and check the fireproof net. Clean or replace the fireproof net if necessary.
- Clean or replace the fireproof net and then follow the opposite action to install the outlet cover plate back.

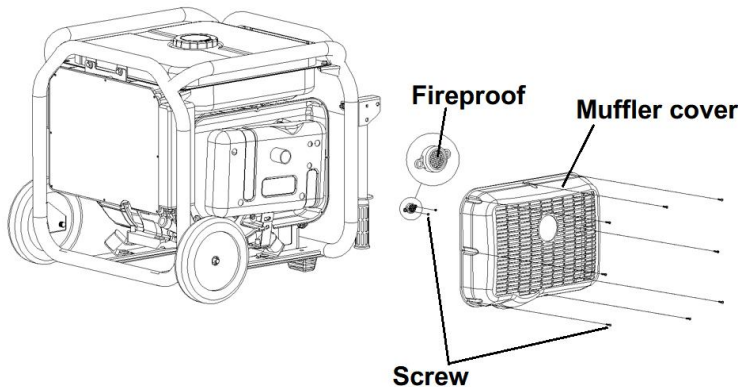

10. TRANSPORTATION/WAREHOUSING

To prevent fuel leakage during transport or temporary storage, turn off the oil switch and place the generator in a location where no fuel leaks.



WARNING

When transporting the generator:

- ◆ Do not fill too much fuel into fuel tank. (There should be no fuel in the filler).
- ◆ Make sure the oil switch is turned to "OFF".
- ◆ Generator should be placed in a stable position to prevent rollover during transportation.
- ◆ When the generator is still in transit, do not run the generator. Remove the generator from the vehicle and use it at the ventilation.
- ◆ When placing the generator in a transport vehicle, avoid placing it in direct sunlight. If the generator is placed in a sealed compartment, the high temperature inside the compartment may cause the fuel to evaporate and cause an explosion.
- ◆ Do not transport the generator on a rough road for a long time. If you have to do so, please drain the fuel before transporting the generator.

Before long-term storage:

- Make sure the storage area is dry and clean.
- Drain all fuel out.



WARNING

- ◆ Under certain conditions, gasoline is extremely flammable and explosive. Stored generators may contain unburned clean fuel. Therefore, fireworks should be prohibited in the area where generators are stored.

- Transfer the gasoline from the tank to the reserve tank. Loosen the carburetor bolt and transfer the gas oil to the reserve tank; loosen the vent bolt, remove the spark plug and pull the coil 3-4 times to drain the remaining gas in the gas pump.

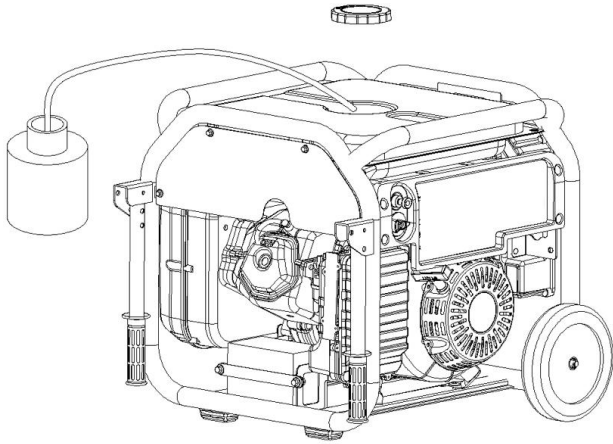

- Exhaust oil. Remove the spark plug, pour a tablespoon of clean oil into the cylinder, pull the start handle a few times to scatter the oil, and then install the spark plug back.
- Pull the handle slowly until it feels pressure. At this moment, the piston is rising to the top of its compression stroke and the exhaust valve is closed. Storage in this case helps prevent rust inside the engine.

11. TROUBLESHOOTING

Cannot start the engine

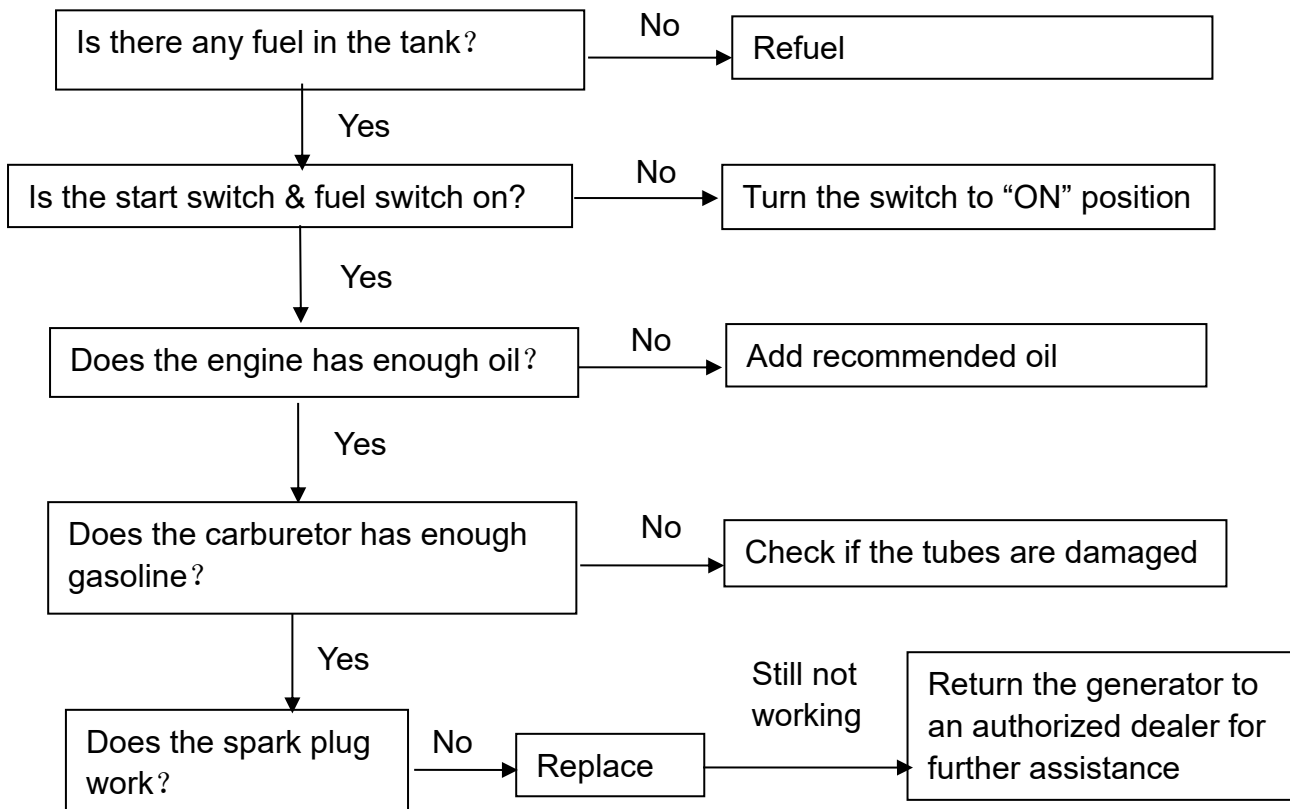



NOTICE

- ◆ If the generator cannot be started for the first time when the oil is added, or the oil is changed, the oil alarm indicator flashes when pulling the start handle, at this time, the generator should be shaken back and forth to ensure that the float of the oil alarm floats. If the generator still does not start, please follow the troubleshooting instruction above.



NOTICE

- ◆ Make sure no fuel spills around the spark plug. Spilled fuel may catch fire.

Check spark plug:

- Remove the ignition coil and clean the dirt around the spark plug.
- Remove the spark plug and insert the spark plug into the ignition coil.
- Connect the spark plug side electrode with wire to the metal part of the engine to ground. (You can use the DC output wire to replace the wire. Use one end of the clip to clamp the metal part of the engine, and the other end connect to the side electrode of the spark plug.)
- Pull the start handle, spark should jump from the gap.



NOTICE

- ◆ Ensure that the engine is cooled down when you check the spark plug, or the high temperature of the engine and spark plug will cause burns.

Connected device does not work

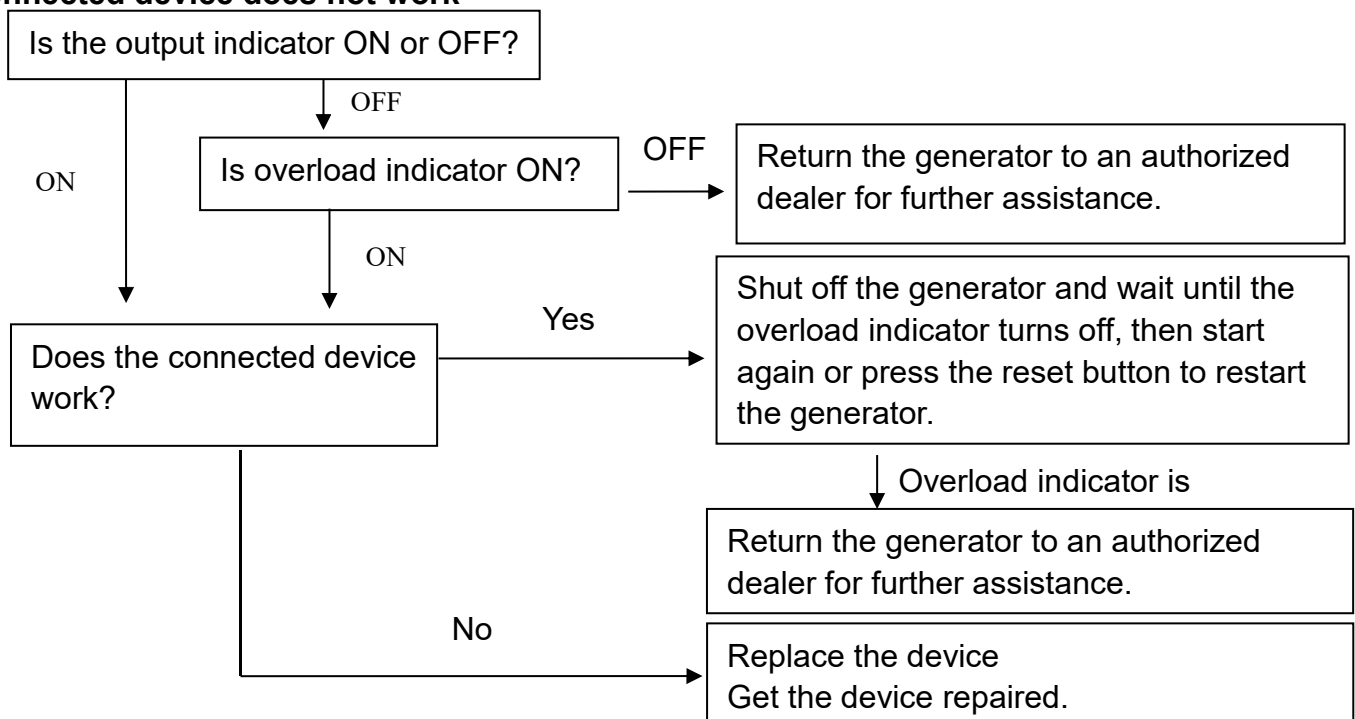

No power in DC socket

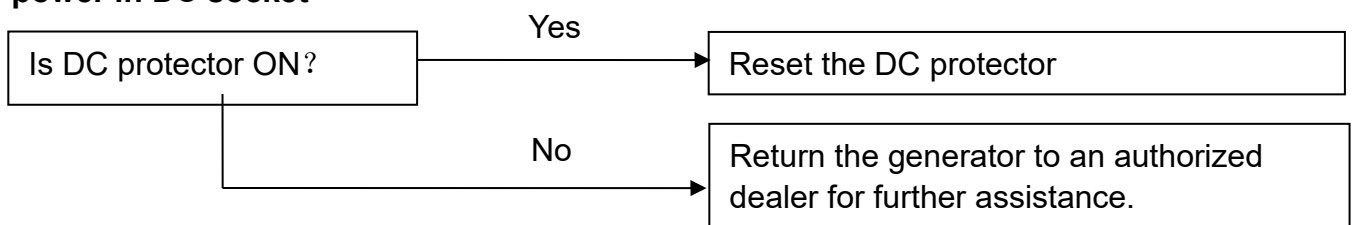

Underpowered

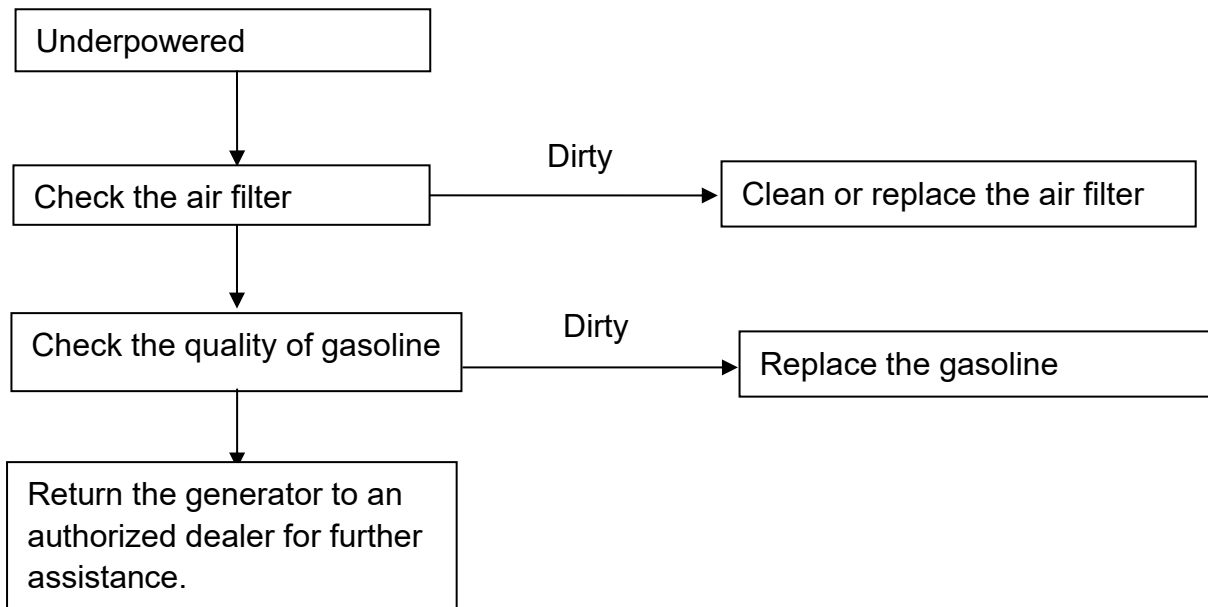

12. SPECIFICATIONS

Engine	Model No.	XG-190F
	Engine type	4-stroke, single cylinder, OHV
	Displacement(CC)	406cc
	Rated speed	3600/min
	Compression ratio	8.2
	Starting system	Electric and Recoil
	Fuel Volume (L)	18L
	Lube. Oil capacity (L)	1.1 L
	Spark plug	F7RTC
	Sound pressure level: L_{pA}	74.7 dB(A), K = 0.93dB(A)
	Sound power level L_{WA}	95.7 dB(A), K = 0.93dB(A)
	Guaranteed sound power level	96 dB(A)
Generator set	AC out put Voltage	230 V~
	AC Frequency	50 Hz
	AC rated output power (COP)	6.3kW
	AC max output power	7.0kW
	AC Rated current	27.4A
	Power factor (cos Φ)	1.0
	Performance class	G1
	Quality class	A
	Max. temperature	40°C
	Max. altitude	1000m
	Protection class	IP23M
	DC output	12V/8.3A
	Length x Width x Height (mm)	470x402x464
	Net weight	65kg

13. CIRCUIT DIAGRAM

XG-KF6500 220V

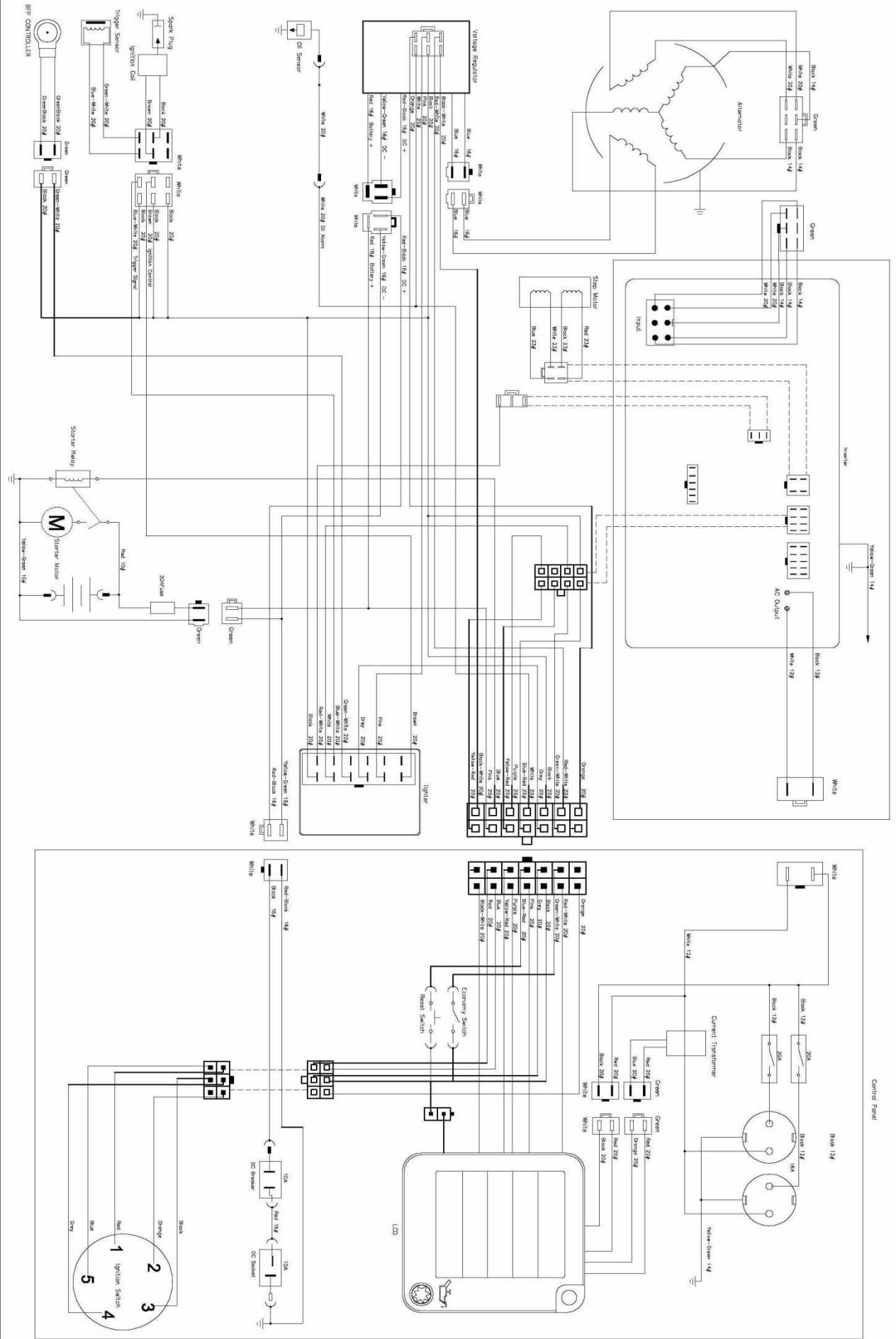

14. CE DECLARATION OF CONFORMITY



BUILDER SAS

32 rue Aristide Bergès - Z.I. du Casque - 31270 Cugnaux - France

Tel : +33 (0)5.34.502.502 Fax : +33 (0)5.34.502.503

States that the designated below machine:

Product: Petrol Inverter generator

Model: FGHI7000ES

Serial number:20220512848-20220512865

is in conformity with the essential requirements and other relevant provisions of the applicable European Directives, based on the application of European harmonized standards. Any unauthorized modification of the apparatus voids this declaration.

European Directives (including, if applicable, their amendments up to the date of signature):

Machinery Directive 2006/42/EC

EMC Directive 2014/30/EC

ROHS Directive (EU) 2015/863 amending 2011/65/EU

Emission directive (EU) 2016/1628 & 2018/989/EU

Noise directive 2000/14/CE Annex VI + 2005/88/CE

European harmonized standards (including, if applicable, their amendments up to the date of signature):

EN ISO 8528-13:2016

EN 55012:2007/A1:2009

EN 61000-6-1:2007

Measured sound power level, L_{wA}: 95.7dB(A) k=0.93dB(A)

Guaranteed Sound power level: 96 dB(A)

Notified body 0359

Intertek Testing & Certification Ltd. Davy Avenue, Knowlhill, Milton Keynes, MK5 8NL

Telephone: +44 (0)1908 857777 Fax: +44 (0)1908 857830 Web: www.intertek.com

Cugnaux: 14/07/2022

Philippe MARIE/PDG

15. WARRANTY



WARRANTY

The manufacturer guarantees the product against defects in material and workmanship for a period of 2 years from the date of the original purchase. The warranty only applies if the product is for household use. The warranty does not cover breakdowns due to normal wear and tear.

The manufacturer agrees to replace parts identified as defective by the designated distributor. The manufacturer does not accept responsibility for the replacement of the machine, in whole or in part, and/or ensuing damage.

The warranty does not cover breakdowns due to:

- insufficient maintenance.
- abnormal assembly, adjustment or operations of the product.
- parts subject to normal wear and tear.

The warranty does not extend to:

- shipping and packaging costs.
- using the tool for a purpose other than that for which it was designed.
- the use and maintenance of the machine done in a manner not described in the user manual.

Due to our policy of continuous product improvement, we reserve the right to alter or change specifications without notice. Consequently, the product may be different from the information contained therein, but a modification will be undertaken without notice if it is recognized as an improvement of the preceding characteristic.

READ THE MANUAL CAREFULLY BEFORE USING THE MACHINE.

When ordering spare parts, please indicate the part number or code, you can find this in the spare parts list in this manual. Keep the purchase receipt; without it, the warranty is invalid. To help you with your product, we invite you to contact us by phone or via our website:

- **+33 (0)9.70.75.30.30**
- **<https://services.swap-europe.com/contact>**

You must create a "ticket" via the web platform.

- Register or create your account.
- Indicate the reference of the tool.
- Choose the subject of your request.
- Describe your problem.
- Attach these files: invoice or sales receipt, photo of the identification plate (serial number), photo of the part you need (for example: pins on the transformer plug which are broken).



16. PRODUCT FAILURE

WHAT TO DO IF MY MACHINE BREAKS DOWN?

If you bought your product in a store:

- a) Empty the fuel tank if your product has one.
- b) Make sure that your machine is complete with all accessories supplied, and clean! If this is not the case, the repairer will refuse the machine.

Go to the store with the complete machine and with the receipt or invoice.

If you bought your product on a website:

- a) Empty the fuel tank if your product has one.
- b) Make sure that your machine is complete with all accessories supplied, and clean! If this is not the case, the repairer will refuse the machine.
- c) Create a SWAP-Europe service ticket on the site: <https://services.swap-europe.com> When making the request on SWAP-Europe, you must attach the invoice and the photo of the nameplate (serial number).
- d) Contact the repair station to make sure it is available before dropping of the machine.

Go to the repair station with the complete machine packed, accompanied by the purchase invoice and the station support sheet downloadable after the service request is completed on the SWAP-Europe site

For machines with engine failure from manufacturers BRIGGS & STRATTON, HONDA and RATO, please refer to the following instructions.

Repairs will be done by approved engine manufacturers of these manufacturers, see their site:

- <http://www.briggsandstratton.com/eu/fr>
- <http://www.honda-engines-eu.com/fr/service-network-page;jsessionid=5EE8456CF39CD572AA2AEEDFD290CDAE>
- <https://www.rato-europe.com/it/service-network>

Please keep your original packaging to allow for after-sales service returns or pack your machine with a similar cardboard box of the same dimensions.

For any question concerning our after-sales service you can make a request on our website <https://services.swap-europe.com>

Our hotline remains available at +33 (9) 70 75 30 30.



17. WARRANTY EXCLUSIONS

THE WARRANTY DOES NOT COVER:

- Start-up and setting up of the product.
- Damage resulting from normal wear and tear of the product.
- Damage resulting from improper use of the product.
- Damage resulting from assembly or start-up not in accordance with the user manual.
- Breakdowns related to carburetion beyond 90 days and fouling of carburetors.
- Periodic and standard maintenance events.
- Actions of modification and dismantling that directly void the warranty.
- Products whose original authentication marking (brand, serial number) has been degraded, altered or withdrawn.
- Replacement of consumables.
- The use of non-original parts.
- Breakage of parts following impacts or projections.
- Accessories breakdowns.
- Defects and their consequences linked to any external cause.
- Loss of components and loss due to insufficient screwing.
- Cutting components and any damage related to the loosening of parts.
- Overload or overheating.
- Poor power supply quality: faulty voltage, voltage error, etc.
- Damages resulting from the deprivation of enjoyment of the product during the time necessary for repairs and more generally the costs related to the immobilization of the product.
- The costs of a second opinion established by a third party following an estimate by a SWAP-Europe repair station
- The use of a product which would show a defect or a breakage which was not the subject of an immediate report and/or repair with the services of SWAP-Europe.
- Deterioration linked to transport and storage*.
- Launchers beyond 90 days.
- Oil, petrol, grease.
- Damages related to the use of non-compliant fuels or lubricants.

* In accordance with transport legislation, damage related to transport must be declared to carriers within 48 hours maximum after observation by registered letter with acknowledgement of receipt.

This document is a supplement to your notice, a non-exhaustive list.

Attention: all orders must be checked in the presence of the delivery person. In case of refusal by the delivery person, it you must simply refuse the delivery and notify your refusal.

Reminder: the reserves do not exclude the notification by registered letter with acknowledgement within 72 hours.

Information:

Thermal devices must be wintered each season (service available on the SWAP-Europe site). Batteries must be charged before being stored.

FEIDER

MACHINES



BUILDER SAS
32 rue Aristide Bergès - Z.I. du Casque - 31270 Cugnaux - France
MADE IN PRC